

# Single Stage Active Power Factor Correction Circuit for Street LED Light with Battery Backup

DOI: 10.36909/jer.ICEPE.19557

Asad Muneer, Ahsan Fayyaz, Shahid Iqbal\*, Muhammad Waqas Jabbar, Arslan Qaisar, Faisal Farooq

Department of Electrical Engineering, Hafiz Hayat Campus, University of Gujrat, 50700, Pakistan

\*Corresponding Author: [si@uog.edu.pk](mailto:si@uog.edu.pk)

## ABSTRACT

This paper proposes a single-stage active power factor correction circuit for street LED light with battery back-up. The buck–boost converter and flyback converter are combined to achieve optimal performance. The first part of the integrated LED driver, the buck–boost converter is used to adjust the power while operating in the discontinuous conduction operation. The second part of the driver, the flyback converter provides regulated voltage to the LEDs. The battery backup circuit charges the battery when ac input power is available and provides power to LED lamp when input power supply is not available. The proposed LED driver was designed for 100 W output power and tested by PSpice simulation. The simulation results obtained are given in the paper to demonstrates the functionality of the proposed LED driver system. The result show good operation and performance of proposed LED driver.

**Keywords:** Converter; Driver; Light-Emitting Diode (LED); Streetlight.

## INTRODUCTION

Electrical lighting is not only the most generic form of artificial lighting, but important technology that affects human’s well-being physically and psychologically. At present, several kinds of lighting sources are existing in the market (Alonso, J. M., Viña, J., Vaquero, D. G., Martínez, G., & Osorio, R. 2012). These includes incandescent, fluorescent, halogen, metal halide, sodium vapor, mercury vapor, and white light-emitting-diodes (LED). The LEDs have very long lifetime, higher energy efficiency and they are environment friendly (Chang, Y. N., Chan, S. Y., & Cheng, H. L., 2018). LEDs are current operated devices; therefore, they need dc

current for their operation (Cheng, C. A., Chang, C. H., Cheng, H. L., Chang, E. C., & Lai, C. C., 2018). Generally, street, and industrial LED lamps are powered using ac utility line. Thus, input to the LED streetlamps is ac while LEDs consumes dc power. Therefore, ac power from utility line needs to be rectified and processed to get desired regulated voltage and current. **LED drivers** are designed to do this job. However, as LEDs are not purely resistive loads (Cheng, C. A., & Wu, H. C., 2018), therefore, LED drivers should have the capability of power factor correction (PFC), lower total harmonic distortion (THD), and high efficiency etc. Therefore, a LED driver for street lighting applications should meet the following key requirements: (1) LED driver for street lamps should satisfy the mandatory power quality requirements stated for the community lighting in the current harmonic standards such as EN 61000-3-2 class C established by the International Electro-Technician Commission (IEC) (Lam, J. C. W., & Jain, P. K., 2015); (2) As the life time of LEDs is more than 20 years, so LED driver should be designed and implemented with consideration of similar life span for ensuring long life operation of LED street lamp; (3) LED driver should be designed to have high efficiency by employing soft-switching techniques to achieve benefits like energy loss reduction, low temperature operation that's leads to longer lifetime and increased reliability, and high frequency operation that enables smaller size etc. (Lee, S. W., & Do, H. L. (2017)). (4) The ripple in the output current of LED driver cause fluctuation in the brightness of emitted light by an LED lamp (Yang, Y., Ruan, X., Zhang, L., He, J., & Ye, Z., 2014). These fluctuations are known as flickering and normally cause headaches, visual impairment and make people uncomfortable. So LED driver should be designed to have totally constant output current or minimum output current ripple through LEDs (P. S. Almeida, D. Camponogara, M. D. Costa, H. Braga, and J. M. Alonso 2015). (5) The other requirements for an LED driver are cost-effectiveness, small size, EMI performance and additional safety requirements that protect the whole system (C. Dilouie, 2004). In literature, several types of LED drivers have been proposed and developed. While many of these LED drivers have good operation and performance as far as aforementioned performance parameters are concerned. However, most of these require large number of components in their implementation which make them expensive and larger in size.

In this paper, a single-stage active power factor correction circuit for street LED light with battery back-up is proposed, designed, and tested using PSpice simulation.

## PROPOSED LED DRIVER WITH BATTERY BACK-UP

### A. STRUCTURE

Figure 1 shows the circuit diagram of the proposed LED driver with battery back-up mechanism. It consists of an input AC source ( $V_{in}$ ), EMI filter ( $L_m, C_f$ ), input rectifier ( $D_1$ -  $D_4$ ), buck-boost converter ( $L_p, C_{dc}, D_5, S_2$ ), flyback converter ( $S_1, T, L_m, D_o$ , and  $C_o$ ), LED Lamp, and battery-back-up circuit which consists of half-bridge switching network ( $S_3, S_4$ ), output filter inductor ( $L_b$ ), and battery ( $V_{bat}$ ). Input source whose purpose is to supply AC power is connected to input rectifier through EMI filter and the output terminals of the input rectifier are connected to buck-boost converter. The output terminals of the buck-boost converter are connected to flyback converter and LED Lamp and battery back-up circuit is connected in parallel with the output terminal of the fly back converter. The battery backup circuit is bidirectional converter which charge the battery when AC input power is available, and it provides power to load when AC input power is not available.

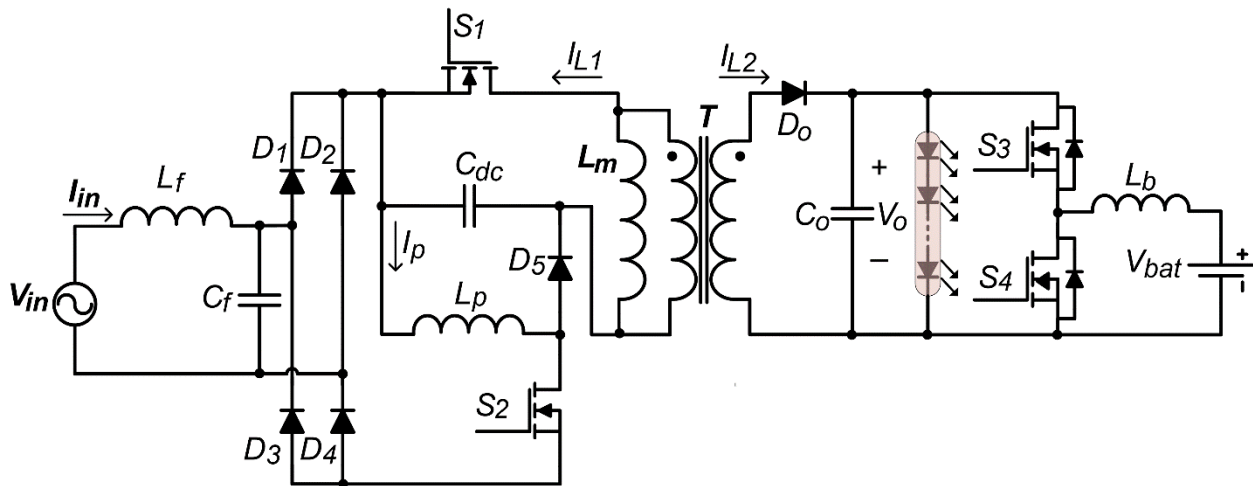
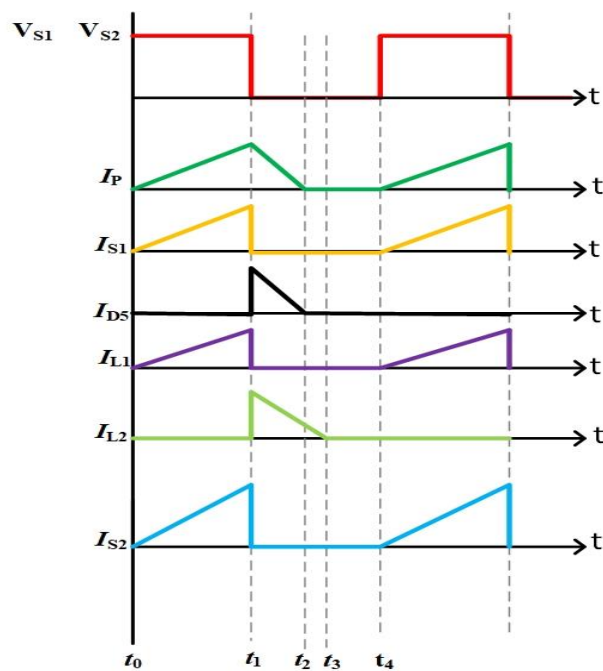

**Figure 1.** Proposed LED driver with battery back-up

### B. PRINCIPLE OF OPERATION

The AC source supplies the rectifier through input EMI filter. Since no filter capacitor is used at the output of the input rectifier, therefore, rectified dc output voltage is produced at the output terminals of input rectifier. This rectified dc voltage is applied at the input of buck-boost converter due to circuit connection. The buck-boost converter operates in discontinuous conduction mode; therefore, it draws current in the form of current pulses from the input rectifier. This current appears as a rectified pulsating current and pulsating AC current at the

output and input sides of the input rectifier, respectively. The input EMI filter removes high frequency ripples from the pulsating AC current and consequently the input current becomes approximately sinusoidal and natural power factor correction is achieved. Accordingly, the proposed LED driver possesses the capability of power factor correction. The output dc voltage of buck-boost converter is provided to fly-back converter as an input voltage and fly-back converter regulates this voltage to the desired level for normal operation of LED lamp and it also provide necessary electrical isolation that is required for safety purpose. The regulated dc voltage of flyback converter is also used to charge the battery. The energy stored in the battery is used to power the LED lamp when main AC supply is not available.



**Figure 2.** Typical timing diagram of steady state operation

### ANALYSIS OF STEADY STATE OPERATION

Following assumption are made to simplify the analysis of proposed LED driver

2. All the components used in the circuit are ideal.
3. The output capacitor and bus capacitors are large enough that ripple across these capacitors is negligible.

Under these assumptions, an operating cycle of the proposed LED driver can be divided into five intervals/modes as shown in the Figure 2. The equivalent circuits related to these four modes are shown in Figures 3–7 . The operation of the LED driver during these four modes is described as:

**Mode 1 ( $t_0 - t_1$ ):** At the beginning of this mode, power switches  $S_1$  and  $S_2$  are turned ON. Three currents loops are formed as shown in the equivalent circuit of Figure 3. Rectified voltage appears across the inductor  $L_p$  and the current  $I_p$  passing through the inductor increases and charges the inductor. This current passes through inductor  $L_p$  and switch  $S_2$ . The other current loop will charge the core of transformer having the path capacitor  $C_{dc}$ , transformer primary magnetizing inductor  $L_1$  and switch  $S_1$ . The  $V_{dc}$  is provided across transformer primary winding  $L_1$ . The voltage across  $L_p$  is defined as

$$V_{p(t)} = V_{rec(t)} \quad (1)$$

Current through inductor will be

$$I_{p(t)} = \frac{V_{rec(t)}}{L_p} (t_0 \rightarrow t_1) \quad (2)$$

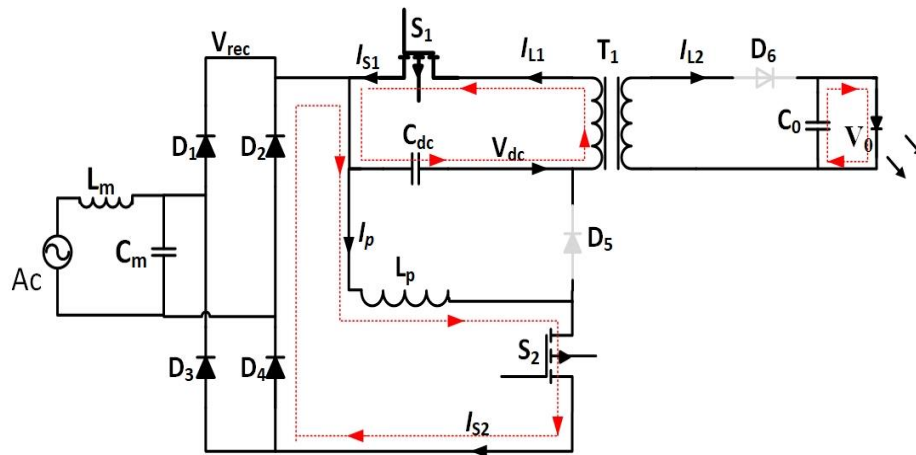

**Figure 3.** Equivalent circuit of Mode 1

The  $V_{dc}$  is attached to the magnetizing inductor  $L_1$  and  $I_{L1}$  passes through primary winding of transformer  $T_1$  and switch  $S_1$  to charge the core of the transformer.

$$V_{L1(t)} = V_{dc}$$

$$I_{L1(t)} = \frac{V_{dc}}{L_1} (t_1 \rightarrow t_0) \quad (2)$$

**Mode 2 ( $t_1 \rightarrow t_2$ ):** The second mode starts when both switches are turn OFF and two current loops are there in second mode. The equivalent circuit of this mode is shown in figure 4. The current  $I_p$  pass through diode  $D_5$  to the charge the capacitor  $C_{dc}$  as soon as the switch  $S_2$  turns off. At this stage the voltage across  $L_p$  will become equal the voltages across  $C_{dc}$ . As the switch  $S_1$  will turns off the current in primary winding of transformer  $T_1$  will diverted in secondary winding of the transformer and this current  $I_{L2}$  make the second loop flowing through LED's at output. At this stage when both switches turn off the current  $I_p$  starts to charge capacitor  $C_{dc}$  so the voltage across inductor will be equal to  $-V_{dc}$  and  $I_p$  decreases.

$$V_{p(t)} = -V_{dc}$$

$$I_{p(t)} = \frac{V_{rec(t)}}{L_p} (t_1 \rightarrow t_0) - \frac{V_{dc}}{L_p} (t_2 \rightarrow t_1) \quad (3)$$

The current in the primary winding is diverted to secondary winding as the switch turns off therefore,  $I_{L1}$  will become zero and  $I_{L2}$  will be:

$$I_{L2} = \frac{N_1 I_{L1}}{N_2} (t_1 \rightarrow t_0) - \frac{V_0}{L_2} (t_2 \rightarrow t_1) \quad (4)$$

The voltage across secondary winding of  $T_1$  will be

$$V_{L2(t)} = -V_0$$

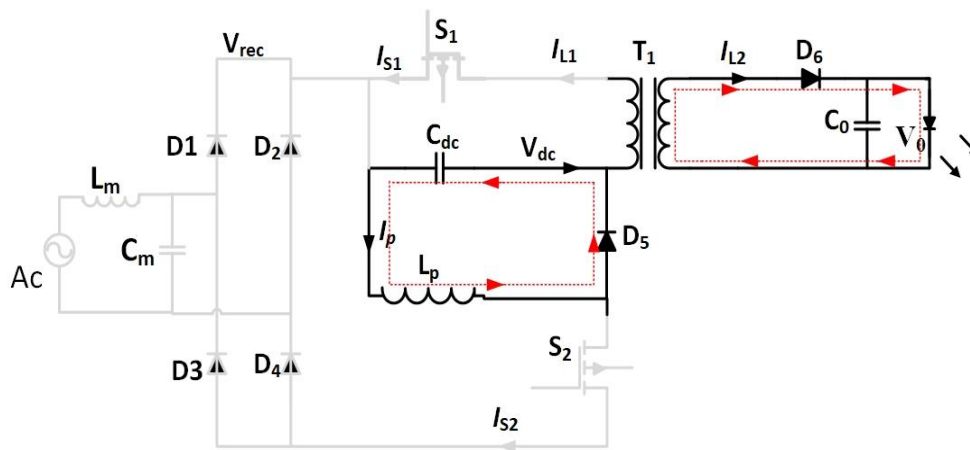

**Figure 4.** Equivalent circuit of Mode 2

**Mode 3a and 3b ( $t_2 \rightarrow t_3$ ):** After mode 2 there are two possible modes depending upon which current reaches to zero first  $I_{L2}$  or  $I_p$ . If  $I_{L2}$  reaches zero first, then mode 3a shown in figure 5 will start and if  $I_p$  end first then mode 3b starts. In mode 3a the output capacitor provides current to output and  $L_p$  is still discharging through diode  $D_5$  to charge the capacitor  $C_{dc}$  but  $I_{L2}$  is zero.

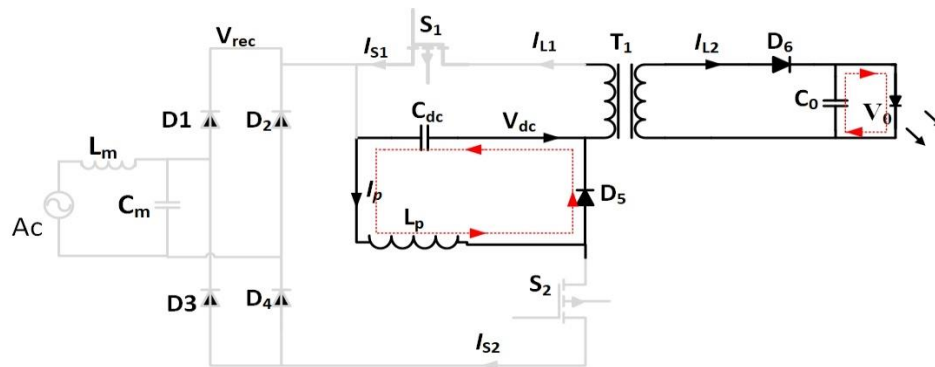

**Figure 5.** Equivalent circuit of Mode 3a

The mode 3b shown in figure 6 starts current  $I_p$  ends first and current  $I_{L2}$  reaches at output.

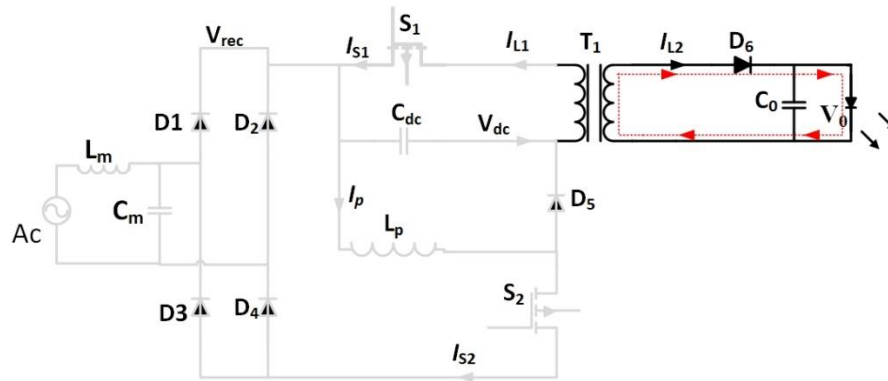

**Figure 6.** Equivalent circuit of Mode 3b

**Mode 4 ( $t_3 \rightarrow t_4$ ):** The fourth and last mode will start when the inductor  $L_p$  is totally discharged and only a single current loop exists at output in which capacitor  $C_0$  provides current to output LED's as shown in figure 7.

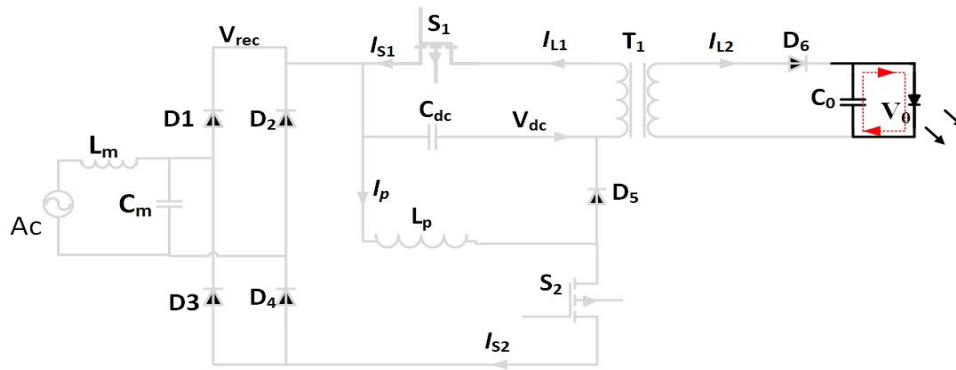

**Figure 7.** Equivalent circuit of Mode 4

## SIMULATION RESULTS

The proposed LED driver was designed for specifications given in Table 1 and the component values of the designed circuit are given in Table 2. To evaluate the operation and performance of proposed LED driver, its circuit was simulated using PSpice software. Simulation of the proposed circuit was carried under different conditions, and its performance is monitored mainly for two different cases discussed in the following.

**Table 1.** Design specifications

Input Voltage	220 Vac
Output Voltage	100 Vdc
Operating Frequency	40 kHz
Power Factor	0.98
Output power	100 W

**Table 2.** Components, Parameters of Proposed Circuit

Components	Parameters
Boost Inductor $L_p$	0.3 mH
DC link Capacitor $C_{dc}$	150 $\mu$ F
Output Capacitor $C_o$	100 $\mu$ F
Low pass Inductor $L_m$	2 mH



Low pass Capacitor $C_m$	0.68 $\mu$ F
Fly-back inductor $L_{TP}$	0.77 mH
Fly-back inductor $L_{Ts}$	0.046 mH
Switching Frequency	40 kHz

### Case 1: Operation at 220V

Figure 8 shows the current waveform of inductor  $L_p$ . The current through  $L_p$  rises in first half cycle when switch  $S_2$  is turned ON and then falls rapidly when the switch is turned OFF. The inductor  $L_p$  is charged in first half and then this inductor current charge the capacitor  $C_{dc}$ . The waveform shows the discontinuous conduction mode (DCM) of current.

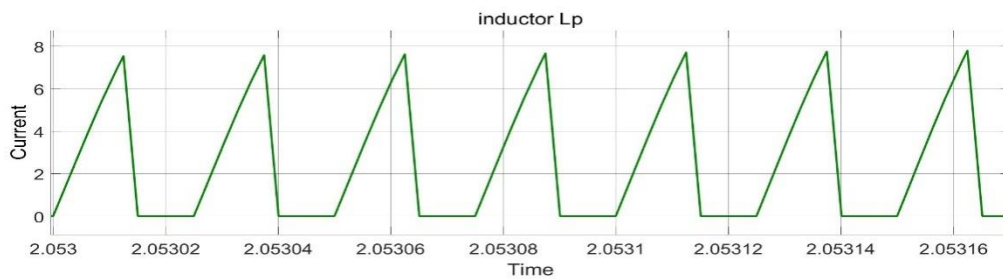

**Figure 8.** Simulated waveform of boost inductor

Figure 9 shows the current of diode  $D_5$ . The diode provides path to discharging current of inductor  $L_p$  and allows the charging of capacitor  $C_{dc}$ . It provides the path to  $I_p$  in second half cycle when switch  $S_2$  is in OFF state. The current  $I_p$  in second half is equal to current diode  $D_5$ . The inductor discharges through the diode  $D_5$  and charge the capacitor  $C_{dc}$ .

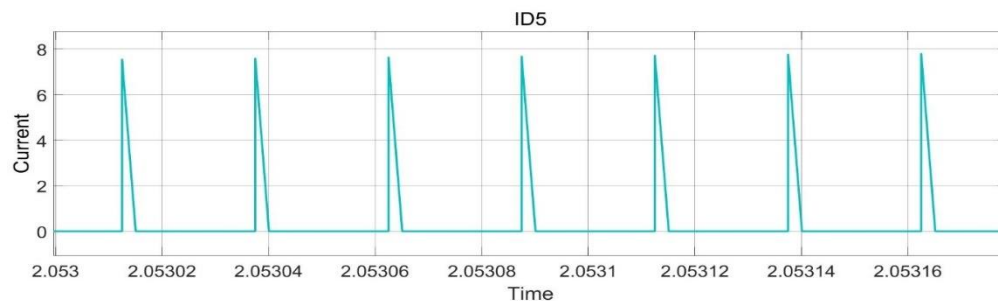

**Figure 9.** Simulated waveform of diode  $D_5$

The current waveform shown in figure 10 is the current flowing through switch  $S_1$ . The current rises when the power switch  $S_1$  is in ON state and the capacitor current in first half cycle pass

through the switch  $S_1$ . In second half there is no current because switch is in off state and no current pass through the switch  $S_1$ .

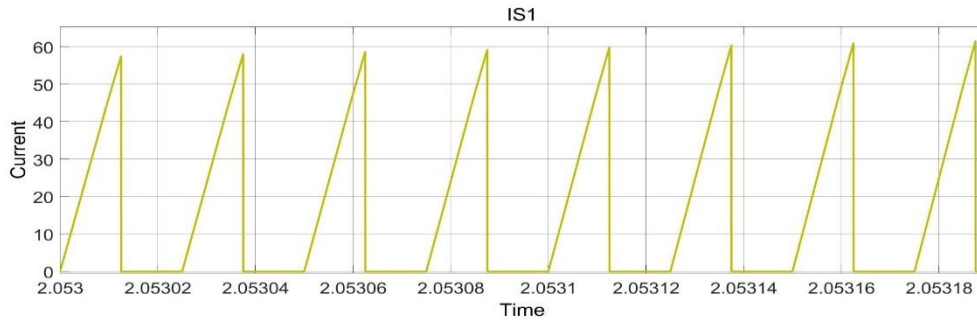

**Figure 10.** Simulated waveform of switch  $S_1$

In figure 11, the current waveform of switch  $S_2$  which rises in first half and turn off in second half as switch  $S_1$ . This current rises with inductor current  $I_p$  and in second half it will become zero.

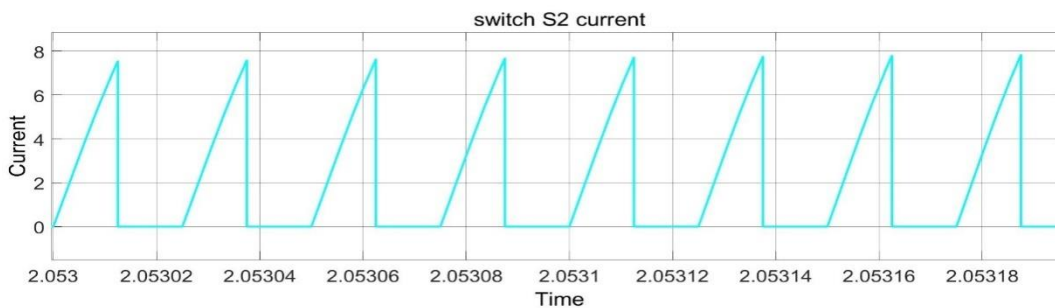

**Figure 11.** Simulated waveform of switch  $S_2$

In figure 12, input voltage and input current are shown. Input current is in phase with input voltage and pure sinusoidal. This sinusoidal waveform of input current represents that power factor is corrected and achieved the low total harmonic distortion (THD). A true power factor is corrected in this proposed circuit which also depends upon the THD.

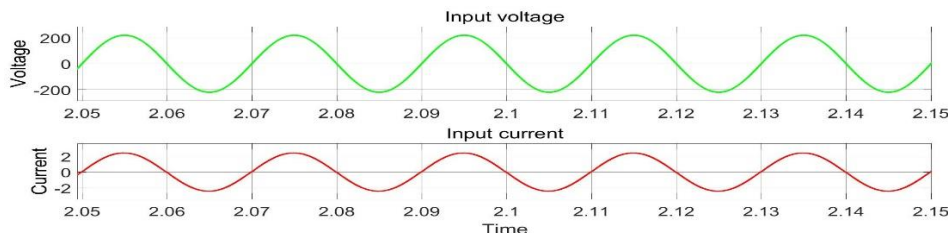

**Figure 12.** Simulated waveforms of input current and voltage

Figure 13 shows the output voltage of the proposed circuit which are stable to operate the LED's at its best. The output voltage is 100 Vdc and the LEDs are designed for 100 W power.

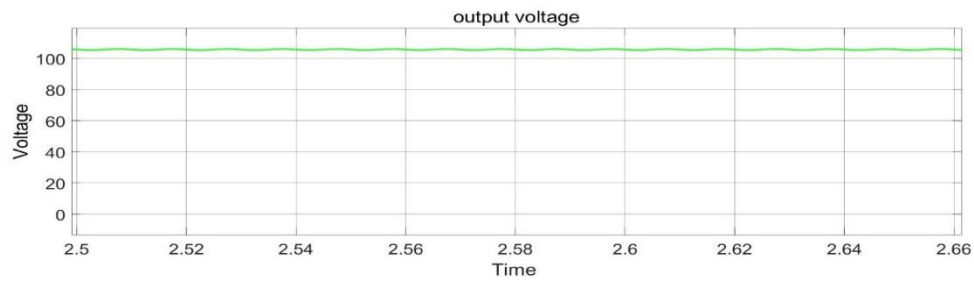

**Figure 13.** Simulated output voltage of proposed circuit

In figure 14, the output current of proposed LED driver is shown which is pure dc current and current is near to 1.02A.

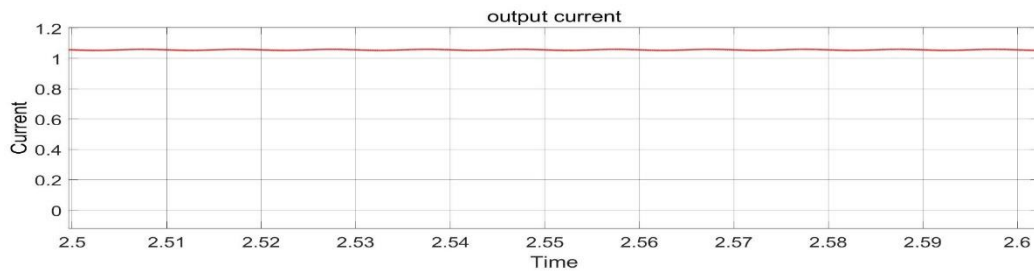

**Figure 14.** Simulated output current of proposed circuit

### Case 2: Operation at 180V

In this case, the input voltage is set at 180 V and simulation results obtained are given in Figures 15 to 22. As shown in figure 15, the boost inductor current rises linearly when switch is turned ON and then linearly reduced to zero when switch is turned OFF. The buck-boost converter is operating in discontinuous conduction mode.

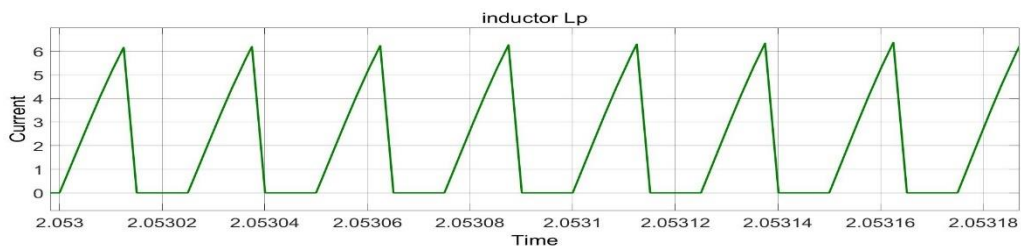

**Figure 15.** Simulated waveform of boost inductor

The switch  $S_1$  current is shown in figure 16. The current rises linearly when switch  $S_1$  is turned on and fall abruptly when switch is turned off.

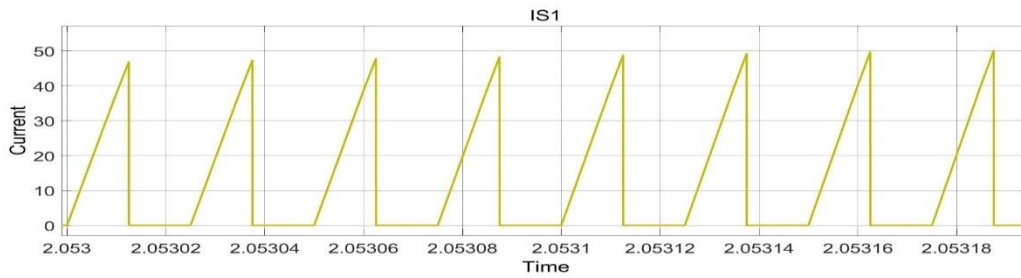

**Figure 16.** Simulated waveform switch  $S_1$

Figure 17 shows the current through switch  $S_2$ . The current rises linearly when switch  $S_2$  is turned on and fall abruptly when switch is turned off.

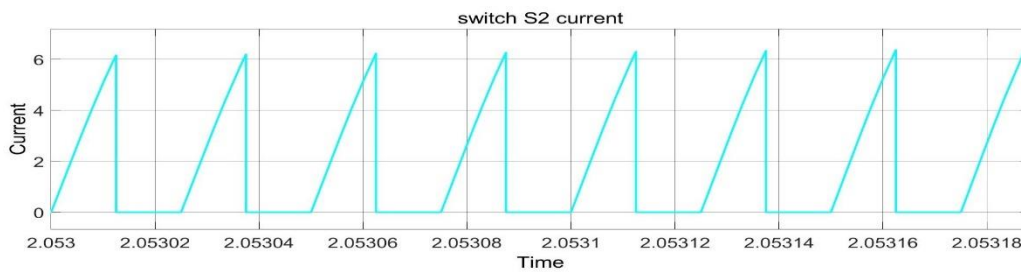

**Figure 17.** Simulated waveform of switch  $S_2$

In figure 18, the current waveform of diode  $D_5$  is shown which shows that the diode conduct for a very short interval of time. The diode  $D_5$  conduct when switch  $S_2$  turns off and  $L_p$  discharge across capacitor  $C_{dc}$ .

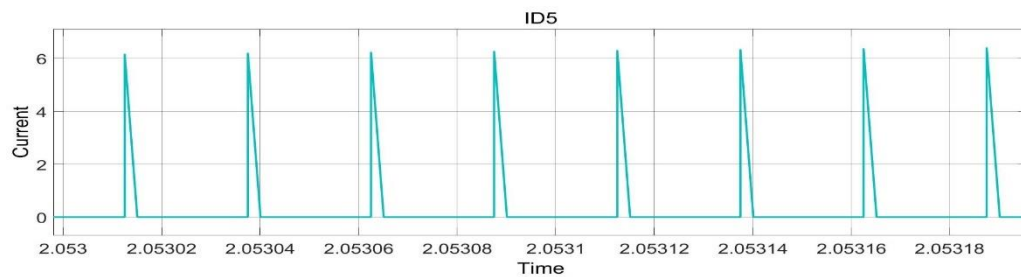

**Figure 18.** Simulated waveform of diode  $D_5$

In figure 19, the input current and input voltage waveform is presented which is sinusoidal and in phase with each other. This shows that the power factor is corrected and is nearly unity.

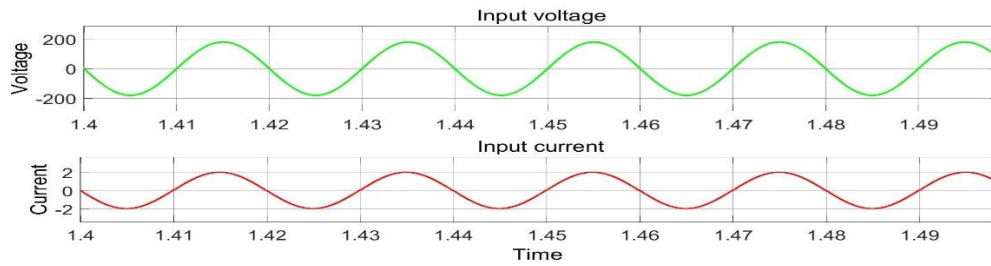

**Figure 19.** Simulated waveform of input voltage and current

The output voltage waveform is shown in figure 20 and dc output voltage is 85 Vdc for the 180 Vac input voltage. The output voltage is pure DC voltage necessary to operate LEDs effectively.

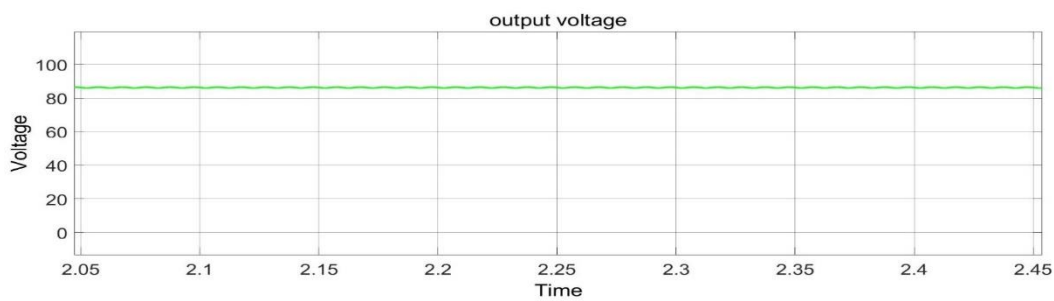

**Figure 20.** Simulated waveform of output voltage

The figure 21 shows the output current which is 0.85 A for input voltage of 180 Vac.

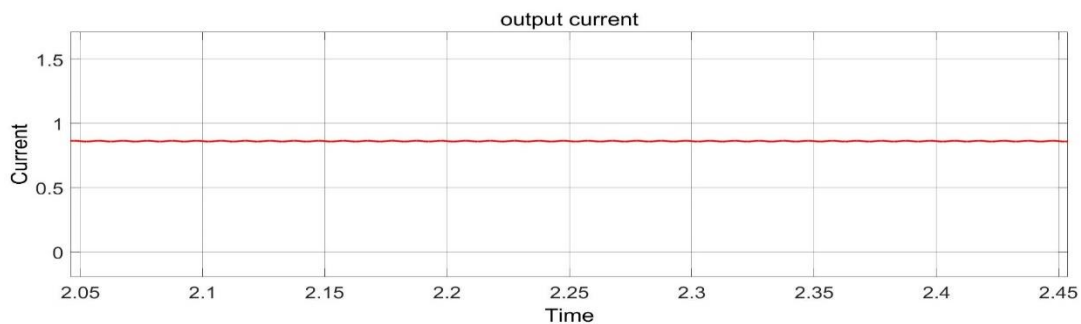

**Figure 21.** Simulated waveform of output current

In figure 22, the state of charge (SOC) shows the battery charging and discharging mode of circuit. First the percentage of battery charging increases which the battery is on charging mode and then in case of no power from source battery provide the power to load. The percentage SOC is decreasing which shows battery is discharging. The waveform VB the voltage at which represents the battery voltage and IB and IB\_ref shows the battery charging and discharging

current. In first half current is negative which shows that the battery is charging and in next half positive current represent the battery discharging and in last waveform named as “Load\_voltage” shows the voltage at load in both charging and discharging modes.

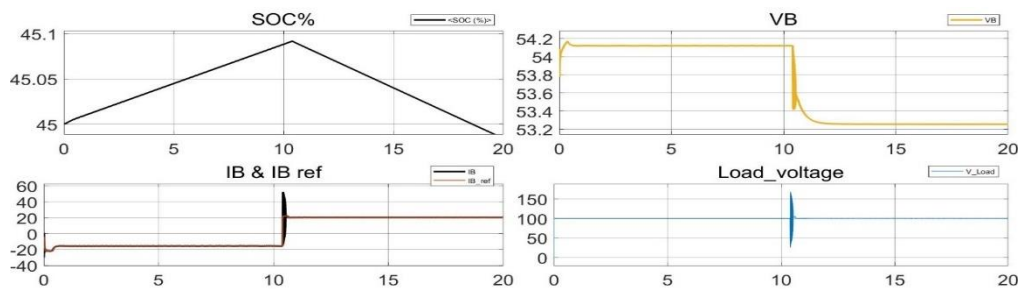

**Figure 22.** Simulated waveform of battery backup circuit

## CONCLUSIONS

This paper proposed a novel LED driver with a single-stage topology having two active switches. This circuit is run by the integration of the buck–boost and fly-back converters. The power factor correction is the main task which is carried out by the buck–boost converter and the buck–boost converter is designed to operate in the discontinuous conduction mode (DCM). The fly-back converter stabilizes the DC link voltages and provides this regulated voltage to LED stings which are placed in parallel. The simulation-based results show that the circuit performance is satisfactory. The measured power factor is 1 in the ideal simulation case and experimentally it should be 0.98 and the efficiency is 0.80.

## REFERENCES

Alonso, J. M., Viña, J., Vaquero, D. G., Martínez, G., & Osorio, R. (2012). Analysis and design of the integrated double buck-boost converter as a high-power-factor driver for power-led lamps. *IEEE Transactions on Industrial Electronics*, 59(4), 1689–1697.

<https://doi.org/10.1109/TIE.2011.2109342>

Almeida, P. S., Camponogara, D., Costa, M. D., Braga, H. and Alonso, J. M., (2015). Matching LED and driver life spans: A review of different techniques," *IEEE Industrial Electronics Magazine*, vol. 9, no. 2, pp. 36-47.

Chang, Y.-N., Chan, S.-Y., & Cheng, H.-L. (2018). A Single-Stage High-Power Factor

- Converter with Synchronized Self-Excited Technique for LED Lighting. *Applied Sciences*, 8(8), 1408. <https://doi.org/10.3390/app8081408>
- Cheng, C. A., Chang, C. H., Cheng, H. L., Chang, E. C., & Lai, C. C. (2018). A Novel LED Tube Lamp Driver with Power-Factor Correction for Indoor Lighting Applications. *2018 IEEE 7th Global Conference on Consumer Electronics, GCCE 2018*, 419–420. <https://doi.org/10.1109/GCCE.2018.8574803>
- Cheng, C. A., & Wu, H. C. (2018). A Novel Single-Stage High-Power-Factor AC-DC LED Power Supply for Streetlight Applications. *2018 IEEE 7th Global Conference on Consumer*
- DiLouie, C. (2004). Controlling LED lighting systems: introducing the LED driver," *LEDs Magazine*, Dec. 2004.
- Lam, J. C. W., & Jain, P. K. (2015). A high power factor, electrolytic capacitor-less AC-input LED driver topology with high frequency pulsating output current. *IEEE Transactions on Power Electronics*, 30(2), 943–955. <https://doi.org/10.1109/TPEL.2014.2309555>.
- Lee, S. W., & Do, H. L. (2017). Boost-Integrated Two-Switch Forward AC-DC LED Driver with High Power Factor and Ripple-Free Output Inductor Current. *IEEE Transactions on Industrial Electronics*, 64(7), 5789–5796. <https://doi.org/10.1109/TIE.2017.2652407>.
- Yang, Y., Ruan, X., Zhang, L., He, J., & Ye, Z. (2014). Feed-forward scheme for an electrolytic capacitor-less AC/DC LED driver to reduce output current ripple. *IEEE Transactions on Power Electronics*, 29(10), 5508–5517. <https://doi.org/10.1109/TPEL.2013.2293353>.