

Ant Colony Optimization based Optimal Tuning of Fractional Order (FO) PID Controller for controlling the Speed of a DC Motor

Neeraj Gupta*, Manjeet Kaur and Rashmi Gupta

Department of Electronics & Communication Engineering, Amity University Haryana, Gurugram, 122413, India.

**Corresponding Author.Email: neerajsingla007@gmail.com; activesweety@gmail.com; goyal.rashmi18@gmail.com;*

Submitted : 18-08-2021

Revised : 14-12-2021

Accepted : 26-12-2021

ABSTRACT

This paper deals with the use of a FOPID Controller for the direct current motor speed controlling process. FOPID Controller consists of fractional integral-derivative terms along with the integer order proportional terms. It is a specific controller in which orders of derivative and integral lie in between fractions of 0 and 1. Mathematical model of DC motor and controller is presented whose field has been excited by an external source. In this paper, the simulation part of a DC motor for controlling its speed using a FOPID Controller has been performed. There are five degrees of freedom in FOPID controller contrary to traditional PID controller which have only three. The values of the five parameters (K_p , K_i , K_d , λ , μ) of a FOPID Controller have been improved by reducing the ITAE (Integral Time Absolute Error) cost to best possible value using the ACO i.e. Ant Colony Optimization Technique. The closed loop ZNT (Ziegler-Nichols Tuning) method used for the tuning of DC motor. Simulink model of proposed system has been developed and simulated to find out the minimum cost. The intensification in the steady and transient behaviors of the system. The results also exhibit significant improvement in the rise time, settling time and peak overshoot as compared to the other optimization methods.

Keywords: DC Motor; PID Controller; ZNT Method; FOPID Controller; ACO.

INTRODUCTION

For most of the manufacturing industries as well as for most of the commercial applications, the electrical drives are considered as the most essential part. DC motors are the widely accepted drives. DC motors have many advantages such as easy control and reliable access and thus are widely accepted in most of the industrial as well as commercial applications. The controlling of the DC motor speed is much required. The closed loop control system is preferred over the open loop control system due to many problems that occurs in case of open loop control system such as ripples in torque, large steady-state error, large overshoot owing to the absence of a feedback to the controller. In other words, in case of closed loop control systems, load position feedback is provided to a controller so in order to reduce the ITAE i.e. Integral Time Absolute Error (Kumar et al.,2017 & Ahuja et al.,2014).

PID controller is among the most widely and popularly accepted automatic controller for various applications in the process industries. The function of the controller is to process and adjust the control inputs to minimize the calculated error (Saleem et al.,2018). The performance of the feedback controller can further be improved by using PID i.e. Proportional-Integral-Derivative controller and its various types proposed. IMC-PID controller, Smith predictor PID controller and Dead- time PID controller are the various examples of the PID controller types. However, PID controllers suffers from poor sensitivity and mitigation in performance for nonlinear and higher order systems. A recently proposed, more generalized PID controller called FOPID. It is also known as $PI^\lambda D^\mu$ controller. In this type of

controller, the order of the differentiator is μ and that of an integrator is λ (Shamseldin et al.,2019).

Many of the techniques have been proposed such as Cohen-Coon rule, Ziegler-Nichols

method, Astrom-Haggüland method, integral performance criterion, modified Ziegler-Nichols scheme etc. for the tuning and designing of the PID as well as the FOPID controllers to overcome the disadvantages such as controller gain sensitivity and large overshoot. In this paper, Ziegler-Nichols tuning method has been applied due to its simplicity. From the various evolutionary techniques (PSO, GA, CBBO, ANFIS and many more), Ant Colony Optimization technique is used to adjust the parameters of the FOPID controller for the betterment of the results and increase the accuracy. In ACO, we are studying the behaviors of the ants to realize and perform various tasks (Ibrahim et al.,2014).

SYSTEM MODELING

DC Motor Model

The separately excited DC motor with respect to the field excitation is considered for the analysis. In these types of motors, the current needed to produce a stronger and healthier stator field is minimized by large number of turns of the field coil. The field current is sovereign of the armature or the load current as the field is excited by an external load (Ldir et al.,2018). The DC motor can work in two different control modes in a control system. In the first mode, the field current is fixed, and thus called the armature control mode while the other one has the fixed armature current and thus called the field control mode. Due to the ability of maintaining, throughout the application, a constant torque level and the field current, the armature control mode motor is used (Pandey et al.,2017). Figure 1 depicts the DC motor.

Where R = Armature resistance, L = inductance of the Armature winding (H)

e_a = Applied Armature Voltage (V), e_b = back e.m.f. (V)

i_a = Armature current (A), and i_f = field current (A)

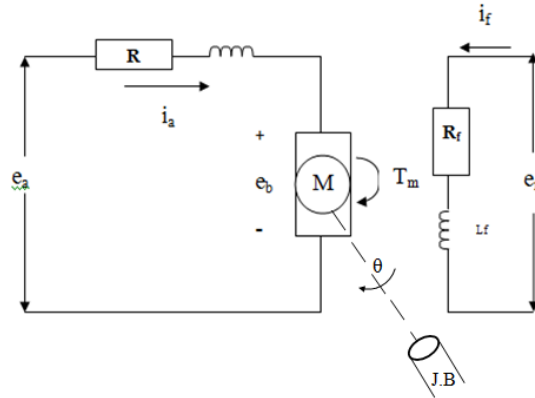

Figure 1 Separately excited constant field current DC Motor

The developed Torque by the motor is T_m (Nm) and the motor shaft's angular displacement is θ (rad. / sec.). When referring to motor shaft, the motor's equivalent moment of inertia is J ($\text{kg}\cdot\text{m}^2$) while the coefficient of the motor's equivalent friction is denoted by B ($\text{Nm}\cdot\text{s} / \text{rad}$). Generally, for the applications having linear range of magnetization curve, the DC motors are preferably used. The flux is directly proportional to the field current, i.e.

$$\phi = K_f i_f \quad (1)$$

K_f is proportionality constant.

K_T is called the motor torque constant which is a constant of proportionality. The back e.m.f. and the speed are also directly proportional to each other. Therefore,

$$e_b = K_b \frac{d\theta}{dt} \quad (2)$$

For an armature circuit, the differential equation would be

$$L \frac{di_a}{dt} + R i_a + e_b - e_a = 0 \quad (3)$$

and thus, the equation for the torque would be

$$J \frac{e^2\theta}{dt^2} + B \frac{d\theta}{dt} - T_m = K_t i_a \quad (4)$$

With the initial conditions as zero, take the Laplace transform and thus,

$$E_b(s) = K_b s \theta(s) \quad (5)$$

$$(Ls + R) I_a(s) = E_a(s) - E_b(s) \quad (6)$$

$$(Js^2 + Bs).\theta(s) = T_m(s) = K_T I_a(s) \quad (7)$$

Thus, the Transfer function can be finalized as,

$$\frac{\theta(s)}{E_a(s)} = \frac{K_T}{s [(R + sL)(Js + B) + K_T K_b]} \quad (8)$$

Or

$$G(s) = \frac{\omega(s)}{E_a(s)} = \frac{K_T}{(R + sL)(Js + B) + K_T K_b} \quad (9)$$

FOPID Controller

Based on the fractional calculus, a FOPID controller is the further generalized form of the traditional PID controller. Along with the three known parameters of a traditional PID controller i.e. K_p (Proportional gain), K_i (Integral gain) and K_d (Derivative gain), there are two more parameters i.e. λ and μ in case of FOPID. The general form of the FOPID is $PI^\lambda D^\mu$. Fractional calculus based conventional PID controller is further expanded into $PI^\lambda D^\mu$ (Tajbakhsh et al.,2014, Narmada et al.,2014, Mohammed et al.,2018, Can et al.,2021 & Zaihidee et al.,2021). The transfer function in case of a conventional PID controller would be

$$G_{PID}(s) = \frac{u(s)}{e(s)} = K_c \left[1 + \frac{1}{\tau_i s} + \tau_d s \right] \quad (10)$$

Similarly, for a FOPID, it would be

$$G_{FOPID}(s) = \frac{u(s)}{e(s)} = K_c \left[1 + \frac{1}{\tau_i s^\lambda} + \tau_d s^\mu \right] \quad (11)$$

Here the arbitrary numbers i.e. λ and μ can attain any real value, K_c = amplification gain. Where τ_i = integration constant, τ_d = differentiation constant

$PI^\lambda D^\mu$ has an advantage of more simplicity and flexibility and thus can adjust the control system dynamics more accurately. Intuitively, on comparison to a traditional PID controller, the degree of freedom is more in terms of FOPID and thus a better performance is expected from $PI^\lambda D^\mu$ with appropriate control parameters. In this work, the

closed-loop Ziegler-Nichols method of tuning is preferred over the open-loop method because of increased accuracy as well as the sensitivity is also improved. Figure 2 reveals the fractional order PID controller.

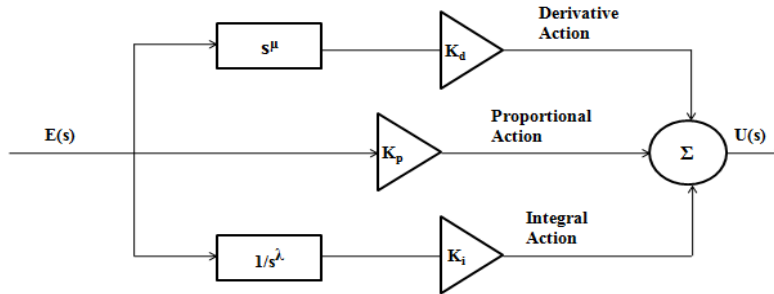

Figure 2 Fractional Order PID controller

ACO-ANT COLONY OPTIMIZATION TECHNIQUE

ACO technique is probabilistic by nature used to solve various computational problems which find appropriate and suitable paths through graphs. The multi-agent methods i.e. artificial ‘ants’ are inspired by the real ant’s behavior. The predominant based on pheromone. These artificial ants are combined with local search algorithms to make a suitable method for various optimizing tasks that involves graphs for example, routing of vehicles or the internet routing. This ACO, for example can be considered as a class of optimizing algorithms modeled on the action and behavior of the ant colony. The simulating agents i.e. artificial ‘ants’ find the optimal and appropriate solutions of the problems moving through a parameter space with all kinds of feasible solutions. The main benefit of using ACO is the confirmation of convergence, adaptive to various

changes like distance, speed, position and providing rapid and appropriate solutions. Although ACO offers splendid benefit but suffers from the uncertainty in convergence time and difficulty in theoretical analysis (Puangdownreong D., 2019 & Almatheel et al.,2017). A perceptible measure of a system’s performance is called the performance index. A control system is considered as an optimal one if its parameters are so adjusted that the index attains an utmost value. Some of the error performance index are: -

- Integral square error, $ISE = \int_0^{\infty} e^2(t) dt$.
- Integral absolute error, $IAE = \int_0^{\infty} |e(t)| dt$.
- Integral time square error, $ITSE = \int_0^{\infty} te^2(t) dt$.
- Integral time absolute error, $ITAE = \int_0^{\infty} t|e(t)| dt$.

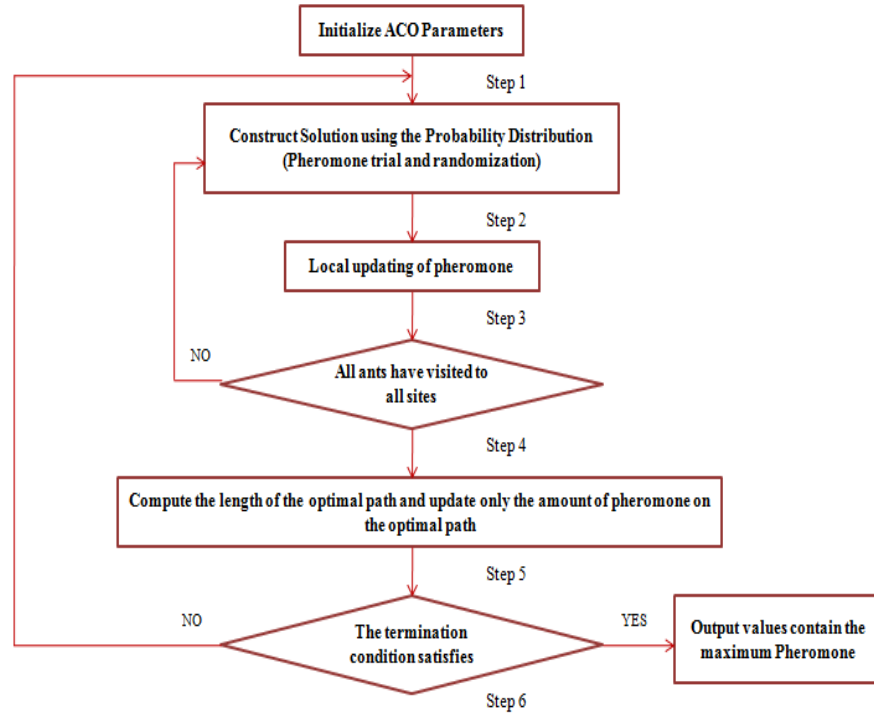

Figure 3 Flow Chart of Ant Colony Optimization technique

In this paper we are minimizing the ITAE cost and thus optimizing the values of the five parameters of the FOPID controller using the ACO technique. Though it is not mathematically analytic, but it is still comparable to ITSE in many aspects (Sondhi et al.,2014). Flow chart of ACO and proposed model is shown in Figure 3 and 4. Out of the various proposed algorithms of ACO, we studied the native Ant System and its most beneficial and popular variant i.e. ACS – Ant Colony System. For understanding the

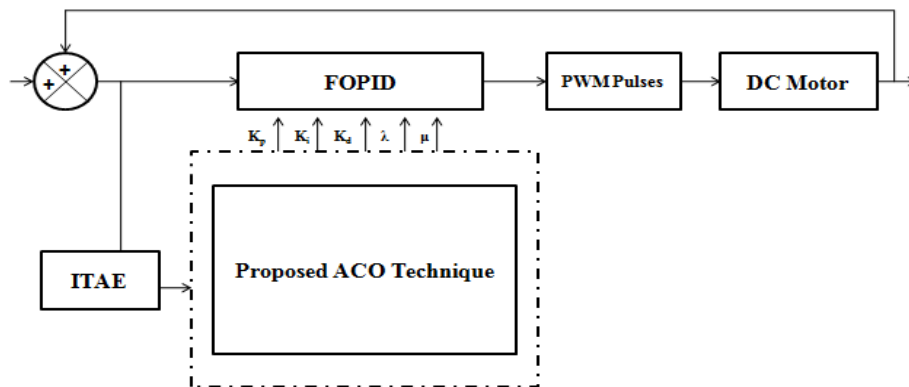

Figure 4 FOPID controller with Proposed Method

differences among the mentioned algorithms, as an example we must be considering one of the famous problems i.e. the travelling salesman problem (Dorigo et al.,2004). The very first proposed ACO algorithm according to the literature in the early 90s is the Ant System (AS). The main property of this algorithm is that the m ants, itself building a solution, updates the values of the pheromone. τ_{ij} pheromone related to the edge that is joining the city i and city j,

is modified as follows: -

$$\tau_{ij} \leftarrow (1 - \rho) \cdot \tau_{ij} + \sum_{k=1}^m \Delta\tau_{ij}^k \quad (12)$$

ρ = rate of evaporation, and m = number of ants

$\Delta\tau_{ij}^k$ = pheromone quantity laid by k^{th} ant on the edge (i, j)

$$\Delta\tau_{ij}^k = \begin{cases} \frac{Q}{L_k} & , \text{if edge (i, j) is used by the } k^{\text{th}} \text{ ant during its tour} \\ 0 & , \text{otherwise} \end{cases} \quad (13)$$

Q = constant and L_k = constructed tour length by the k^{th} ant.

Using the stochastic mechanism, the probability of visiting the city j by the k^{th} ant, after constructing s^p i.e. the partial solution by visiting the city i, is proposed by: -

$$P_{ij}^k = \begin{cases} \frac{\tau_{ij}^\alpha \tau_{ij}^\beta}{\sum_{c_{il} \in N(s^p)} \tau_{il}^\alpha \tau_{il}^\beta} & , \text{if } c_{ij} \in N(s^p) \\ 0 & , \text{otherwise} \end{cases} \quad (14)$$

$N(s^p)$ = suitable components set of edges*(i, l) with l as a yet not*visited city by the k^{th} ant.

The pheromone relative importance is controlled by α , β parameters

$$n_{ij} = \frac{1}{d_{ij}} \quad (15)$$

n_{ij} = heuristic information, d_{ij} = distance from i^{th} city to j^{th} city

According to this algorithm, the pheromone update is added on with a local pheromone update (or the offline pheromone update) taking place after the end of each construction process (Garcia et al.,2002). After each step of constraints, all the ants are performing this local pheromone update process. It is applied onto the last traversed edge by each ant: -

$$\tau_{ij} = (1 - \varphi) \cdot \tau_{ij} + \varphi \cdot \tau_o \quad (16)$$

φ = coefficient of pheromone decay $\in (0,1]$ and τ_o = pheromone initial value.

The main aim of this update is of diversifying the performed search during the iterations by the following ants. The concentration of the pheromone on the edges already traversed is decreased, encouraging the following ants to go for a different edge and thus, updating the solution. During the iteration, the possibility of the produced solutions by the various ants to be identical is decreased (Ning et al.,2018).

Thus, the update formula is given by: -

$$\tau_{ij} \leftarrow \begin{cases} (1 - \rho) \cdot \tau_{ij} + \rho \cdot \Delta\tau_{ij} & , \text{if (i, j) is belonging to the best tour;} \\ \tau_{ij} & , \text{otherwise;} \end{cases} \quad (17)$$

where, $\tau_{ij} = \frac{1}{L_{\text{best}}}$.

RESULTS & DISSCUSSION

A Simulink Model is developed depends on the block diagram shown in Figure 4 for controlling the DC Motor speed using a FOPID controller and depicts in Figure 5. The values of the five parameters of FOPID ($K_p, K_i, K_d, \lambda, \mu$) are optimized using the ACO algorithms by minimizing the value of the objective function. We performed different numbers of iterations in order to curtail the value of the created objective function i.e. ITAE cost and get the best possible set of solutions.

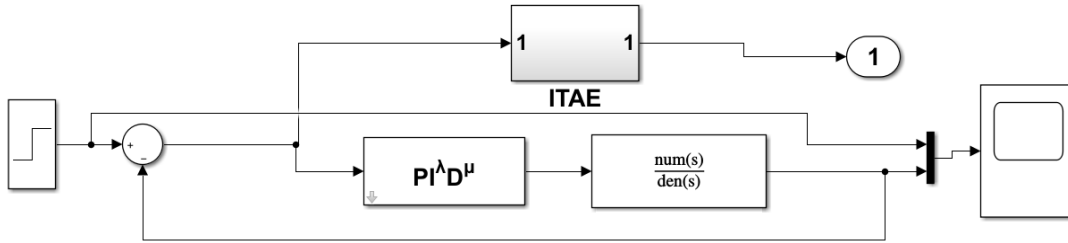

Figure 5 Simulink Model of an ACO based FOPID Controller

In Table 1, the values of the five FOPID Controller parameters are compared for different number of iterations during the tuning of the Controller using ACO technique. The unit step response for controlling DC Motor speed using the FOPID controller tuned by using the ACO algorithms with different number of iterations is shown in Figure 6.

Table 1 Comparison of the control parameters of different number of iterations

M	K_p	K_i	K_d	λ	μ
50	0.1690	9.3526	1.0411	0.9920	0.2064
100	2.5084	9.5014	1.0581	1.0284	0.2395
150	0.19896	8.1567	0.94121	0.091926	0.10075
200	0.9458	9.3326	1.5353	1.1472	0.0281
250	0.7188	9.7382	0.7853	1.0158	0.0574
300	0.1270	9.6713	1.0331	0.9894	0.0724

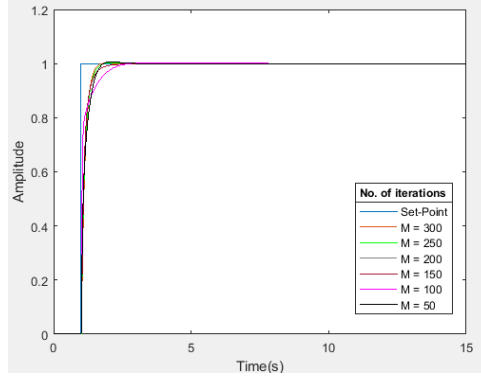

Figure 6 Step response of Speed Control of DC Motor with FOPID

From the Table 2, it is found that for $M = 150$ iterations, the characteristics of the step response obtained are the most suitable in comparison to those obtained with other number of iterations as the peak overshoot is less with small settling time, rise time and peak time. Table 2 depicts the comparison of the objective function for various number of iterations, and it is found that for $M = 150$ iterations the value of the ITAE cost function is minimum. It is found from Figure 7 that the values of the control parameters obtained for $M = 150$ iterations are the most suitable in comparison to the results obtained for the other iterations and thus, the combinations for $M = 150$

are accepted for ACO tuned FOPID Controller.

Table 2 Comparison of Peak Overshoot, Rise Time, Peak Time, and Settling Time

M	M_p (%)	t_r (sec.)	t_p (sec.)	t_s (sec.)	ITAE cost
50	0.7	0.7964	2.073	1.84	0.1823
100	0.2	0.46	3.11	2.833	0.1993
150	0.016	0.287	1.99	2.243	0.1580
200	0.316	0.447	3.49	2.8	0.2234
250	0.3	0.308	2.006	1.76	0.17241
300	0.1	0.295	1.902	1.764	0.1685

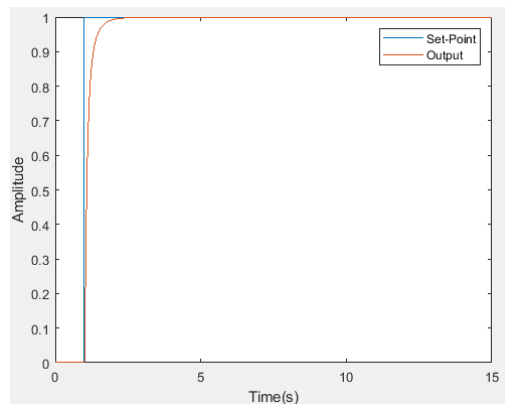

Figure 7 Unit Step Response of ACO tuned FOPID Controller ($M=150$)

Table 3 shows the comparison of the characteristics of the resultant step response using the ACO and different techniques (Particle swarm optimization, Differential evolution, Genetic algorithm, and Adaptive network-based fuzzy inference system) in the previous research made (Ahuja et al.,2014, Pandey et al.,2017, Narmada et al.,2014, Kaur et al.,2020, & Guo et al., 2020). From this comparison, we can see that the results obtained in this work are more beneficial from the

point of industrial use with minimum overshoot and relevant settling time and rise time than that obtained using the other techniques.

Table 3 Comparison of results obtained using different techniques

Technique Used	M_p (%)	t_s (sec.)	t_r (sec.)
ACO	0.016	2.243	0.287
PSO	0.5058	2.7025	0.763
DE	4.67	0.72	0.65
GA	31.105	0.0486	0.0074
ANFIS	7.77	1.66	6.08

CONCLUSION

FOPID controller has been designed in this paper so as for the DC Motor speed control process. For such a system in accordance with the MATLAB environment, FOPID controller was successfully designed and simulated. The derivation of the mathematical model of armature current controlled DC motor was done which helps in describing the speed control system dynamics. For tuning the respective parameters of the controller, ACO optimization and Ziegler-Nichols method of tuning along with the ACO technique has been successfully used in this study. Comparison was done under unit-step signal based on settling time, rise time and overshooting parameters for the evaluation of the proposed speed control system. As it was seen in previous studies that the PID Controller was mostly used in the studies, but we have used the FOPID Controller as the performance characteristics such as overshoot, rise time and settling time are improved and better in its case. Since two additional parameters are included in the FOPID

Controller, its robust design is hard to compare to conventional PID Controller. Therefore, we tried to reduce the ITAE by optimizing all the five parameters of the FOPID Controller. The ITAE between the output of reference model and the plant are minimized to determine the FOPID controller parameters. It has been observed from the results of the simulation process of FOPID controller, ACO running method had minimal overshoot value with a small settling time. It has been observed that the ITAE was reduced, and the results were more precise. Therefore, it shows that FOPID technique can be adopted effectively for the designing of an efficient controller of speed control system for DC motor.

REFERENCES

- Kumar, P., Chatterjee, S., Shah, D., Saha, U.K., & Chatterjee, S.,2017.** On comparison of tuning method of FOPID controller for controlling field controlled DC servo motor. *Cogent Engineering*. 4(1): 1–20.
- Ahuja, A., & Aggarwal, S.K.,2014.** Design of fractional order PID controller for DC motor using evolutionary optimization techniques. *WSEAS Transaction System Control*. 9(1):171–182.
- Shamseldin, M. A., Sallam, M., Bassiuny, A. M., & Ghany, A. M. A.,2019.** A new model reference self-tuning fractional order PD control for one stage servomechanism system. *WSEAS Transaction System Control*. 14: 8–18.
- Ibrahim, H. E. A., & Mahmoud, A. A. H.,2014.** DC motor control using PID controller based on improved ant colony algorithm. *International Review of Automatic Control*. 7(1): 1–6.
- Idir, A., Kidouche, M., Bensafia, Y., Khettab, K., & Tadjer, S. A.,2018.** Speed control of DC motor using PID and FOPID controllers based on differential evolution and PSO. *International Journal of Intelligent Engineering System*. 11(4): 241–249.
- Pandey, N. D., & Tiwari, P.,2017.** Efficient Fractional Feedback Speed Controller in DC Motor Using FOPID Fed with PSO. *International Journal of Science Research*.6(3):,2376–2384.
- Saleem, A., Soliman, H., Al-Ratrout, S., & Mesbah, M.,2018.** Design of a fractional order PID controller with application to an induction motor drive. *Turkish Journal of Electrical Engineering Computer Science*. 26(5): 2768–2778, 2018.
- Tajbakhsh, H., & Balochian, S.,2014.** Robust Fractional Order PID Control of a DC Motor with Parameter Uncertainty Structure. 1(6): 223–229.
- Narmada, R., & and Arounassalame, M.,2014.** Design and performance evaluation of fractional order controller for brushless DC motor. *International Journal of Electrical Engineering Informatics*. 6(3): 606–617.
- Mohammed, I. K., & Abdulla, A. I.,2018.** Fractional Order PID Controller Design for Speed Control DC Motor based on Artificial Bee Colony Optimization. *International Journal of Computer Applications*. 179(24): 43–50.
- Can, E., & Toksoy, M., S.,2021.** A flexible closed loop (fcl) pid and dynamic fuzzy logic + pid controllers for optimization of dc motor. *Journal of Engg. Research*. 1-13.
- Zaihidee, F., M., Mekhilef, S., & Mubin, M., 2021.** Fractional order PID sliding mode control for speed regulation of permanent magnet synchronous motor. *Journal of Engg. Research*. 9(3):209-218.
- Puangdownreong, D.,2019.** Fractional order PID controller design for DC motor speed control system via flower pollination algorithm. *Transaction on Electrical Engineering*. 17(1): 14-23.
- Almatheel, Y. A., & Abdelrahman, A., 2017.** Speed control of DC motor using Fuzzy Logic Controller. in proceeding of International Conference on Communication Control, Computer Electronics Engineering. 1–8.
- Sondhi, S., & Hote, Y. V., 2014.** Fractional order PID controller for load frequency control. *Energy Conversion and Management*.85:343–353.

Dorigo, M., Birattari, M., & Stützle, T., 2004. Relationship between Genetic Algorithms and Ant Colony Optimization Algorithms. *Quality*.11(4):1–16.

García, O.C., Triguero,F.H., & and Stützle,T.,2002. A review on the ant colony optimization metaheuristic: basis, models and new trends. *Mathware & soft Computing*. 9(3):141–175.

Ning, J., Zhang, C., Sun, P., & Feng, Y.,2018. Comparative study of ant colony algorithms for multi-objective optimization. *Information*. 10(1): 1–19.

Kaur, M., Kumar, A., & Luhach, A., 2020. Optimum Design of PID Controller Using Multi-Objective CBBO Algorithm. *International Journal of Scientific & Technology Research*. 9(1): 68-73.

Guo, Y., & Mohamed, M., E., A.,2020. Speed Control of Direct Current Motor Using ANFIS Based Hybrid P-I-D Configuration Controller. *IEEE Access*. 8: 125638-125647.